

# Technical Data Sheet

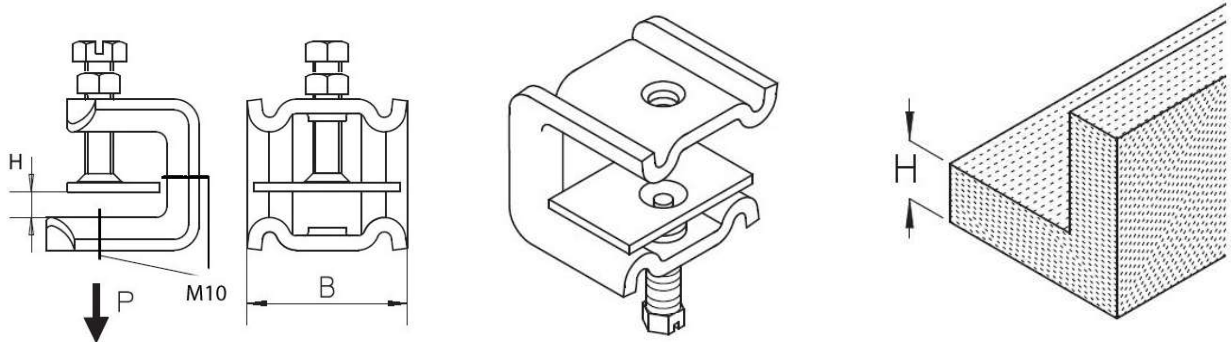

**MKD15/21 M10 Clamp (with locknut)**

**M10 MKD**



All dimensions are in mm; tolerances according to ISO 2768 m-H

## Description

GCA Ltd range of beam clamps (CTLs) offer a very high quality solution for clamping to flat metal surfaces and angle iron in outdoor applications.

## Dimensions

Bolt Hole Size	M10
Dim H (mm)	6-22
Dim B (mm)	44
Dim P (N)	1.5kN Loading
Pack Qty	10
Box Qty	100
Material (Body)	Hot Dipped Galvanised Steel
Material (Bolt & Nut)	A4 316 Stainless Steel
Weight (Kgs)	0.188
Locknut	Yes
Bolt Hole Size	M10
Torque	4Nm

While the information has been carefully compiled to the best of our knowledge, nothing is intended as representation or warranty on our part and no statement herein shall be construed as recommendation to infringe existing patents. In the effort to improve our products, we reserve the right to make changes judged to be necessary.

Draft	Date	Approved	Date	Rev.	Engineering change number	Name	Date
L.Wesley	01/06/23	L.Wesley	01/06/23	1	10003621	M.W	01/06/23
GCA Ltd Ronell Place, 41A Shire Hill Industrial Estate, Saffron Walden, Essex, CB11 3AQ www.gca.co.uk						Tel – 01799 516016 Email – sales@gcald.co.uk	
						Page 1/2	